

# Amputee legrest

## User manual / Assembly instructions

Page 1 (1)

Art. no: 62771, -72, 63771, -72, 64771, -72 and 65771, -72

### Parts included:



### Assembly

The amputee legrest is assembled as follows:

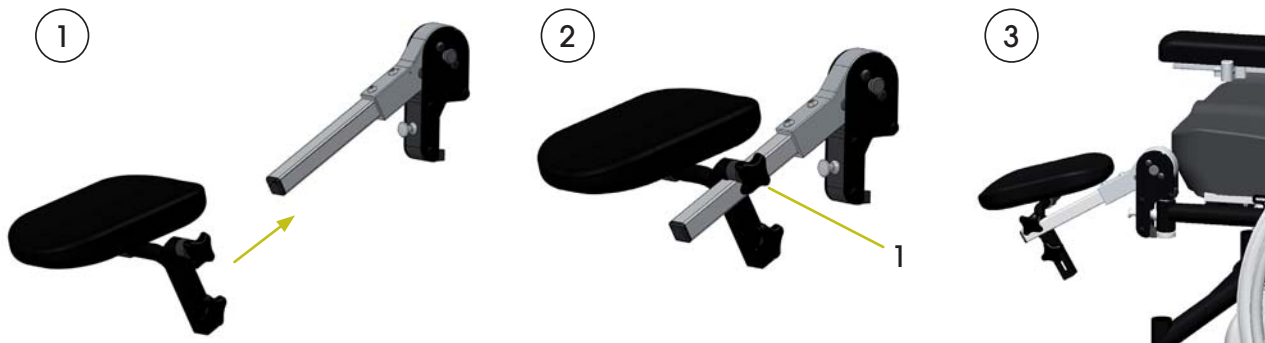

1. Mount the calf support on the tube according to the picture.
2. Tighten the knob (1) to lock the support in position.
3. Mount the legrest on the wheelchair and turn it until it locks in position with a "click".

### Adjustment of position

**Angle.** Hold the legrest and push the button (1). Adjust the angle and release the button. Make sure the legrest is locked in a position! 

**Length.** Loosen the knob (2) and adjust to the desired position along the tube. Tighten the knob.

**Depth.** Loosen the knob (3) and adjust the depth of the support to the desired position. Tighten the knob.

**Lateral adjustment** (as of spring 2015). Loosen the screw (4) and adjust the support laterally to the desired position. Tighten the screw.

### Remove or swing away the whole legrest:

Pull the knob (5) and lift or rotate the legrest.

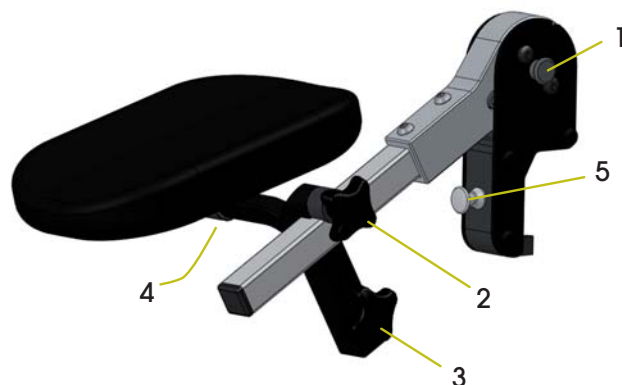

### Care instructions

Wipe with soap and water when needed. For further information, see the Maintenance Instructions 95730-1.



- Risk for pinching hand when adjusting the angle of the legrest. Be careful!
- Using amputee legrest increases the risk of the wheelchair tipping backwards. Use the antitip devices!