

# AD balance

► User Manual | English



**This manual is available in PDF format at [hdrehab.com](https://hdrehab.com).**

# CONTENTS

<b>1. Warranty</b>	<b>4</b>	<b>4. Accessories</b>	<b>16</b>
		4.1 Headrest / Neck rest	16
<b>2. General information</b>	<b>5</b>	4.2 Bag hook	16
2.1 Intended use	5	4.3 Thoracic support	17
2.2. General safety aspects	5	4.4 Table	17
2.3 Tests	6	4.5 Pommel	18
2.4 Identification of the wheelchair	6	4.6 Positioning Belt / Harness	18
2.5 The wheelchair parts	7	4.7 User Card	19
2.6 Delivery Inspection/Installation	7		
2.7 Symbols / Markings	7	<b>5. Transport</b>	<b>19</b>
<b>3. Functions and Settings</b>	<b>8</b>	5.1 Transport of wheelchair with patient in vehicles	19
3.1 Brakes	8	5.2 Weight of removable components	20
3.2 Wheels	9	5.3 Folding the wheelchair for transportation	20
3.3 Antitip device/tipping bar	9	5.4 Transferring in and out of the wheelchair	20
3.4 Push bar	10	5.4 Driving technique	21
3.5 Separate operating handles	10		
3.6 Covers / Cushions	10	<b>6. Maintenance and Care</b>	<b>22</b>
3.7 Seat tilt & Recline function	11	6.1 Daily functional checks	23
3.8 Backrest Height	12	6.2 Long term storage	23
3.9 Setting the Flexi-Back	12	6.3 Recycling and disposal	23
3.10 Adjustable seat / seat depth	13		
3.11 Armrests	13	<b>7. Technical data - Measures</b>	<b>24</b>
3.12 Leg rests	14		
3.13 Footrest	15		
3.14 Calf support	15		



**THANK YOU FOR CHOOSING A WHEELCHAIR FROM HD REHAB,  
WE HOPE IT WILL SERVE YOU WELL**

## WE MANUFACTURE QUALITY OF LIFE

**HD Rehab helps people achieve an improved quality of life. Our products help make the lives of users, their families, and caregivers easier, safer, and more comfortable.**

HD Rehab offers assistive products for people living with disability. Our primary product is wheelchairs, which we have been designing, developing, and manufacturing for over 40 years. We accept no compromises in quality. Precision, safety for user and caregiver, function, and design are our guiding principles. We are confident that you will feel the difference compared to any other wheelchair.

## GLAD TO BE FLEXIBLE

Whether you are a user, a family member, or a caregiver, we welcome your requests and opinions. Our designers and developers work closely with the production team at our facility on the island of Lidingö in Stockholm. Our creative employees use their specialist knowledge, experience, and inventiveness to find solutions for the unique needs of each individual.

## 1. WARRANTY

The warranty is only valid if the product is used as directed and the service and cleaning instructions are followed.

### THE WARRANTY COVERS:

Frame	5 years against defects in materials, manufacturing and/or assembly.
Leg-/arm-/headrests	Two years against defects in materials, manufacturing and/or assembly.
Upholstery	Two years against defects in materials and faults in manufacture.
Gas springs	Two years against defects in materials and faults in manufacture.

### WARRANTY & LIMITATION OF LIABILITY

HD Rehab assumes no liability for damages arising out of the following:

- That the instructions in the manual were not followed.
- Incorrect installation or setup by a third party other than HD Rehab.
- Unauthorized modifications/adaptations.
- Use of spare parts from other manufacturers than HD Rehab if they are not mentioned in the document "Permitted modifications", 95724-1.
- Use by persons weighing more than the maximum user weight stated on the chair.
- That the wheelchair is adjusted to an inappropriate position or setting for the user.

## 2. GENERAL INFORMATION

HD Balance is a class 1 CE labelled medical device.

### 2.1 Intended use

The wheelchair model HD Balance 24 is a manual wheelchair designed for users who can propel themselves to a certain extent. This model can also be used by users who cannot propel themselves.

The wheelchair model HD Balance 16 is a manual wheelchair designed for users who cannot propel the wheelchair themselves.

Both models are intended for use by users in need of much comfort and support when seated. The seat and back on both models can be tilted in various positions to give the user a varied position during activity and rest. A varied seat position is very important. Note that prolonged sitting without a position change can lead to discomfort and excessive pressure. If injury is suspected, look for information regarding symptoms and contact the health care system.

A medical professional should always be consulted prior to using an HD Balance wheelchair. This applies to both new and used wheelchairs. Note that a new prescription may be needed if a user's disability changes or new needs arise. All prescription and adjustment of the wheelchair must be carried out by qualified personnel.

Where the wheelchair has several users, each patient's specific needs must be taken into account. In addition, the chair's upholstery on the back and seat cushions must be washed or changed for each user. Washing instructions are on the seat and cushion covers.

If the user has a pattern of movement or behaviour that strains the chair excessively a strengthened frame version and one piece footrest and calf support must be used. This includes users with significantly increased tonus/spasticity.

The wheelchair is approved for use as a seat during transportation in vehicles.

### 2.2. General safety aspects

HD wheelchairs are intended for use both indoors and outdoors. Before using the wheelchair, it is important that users and carers are familiar with how the chair works and should be used.

Test the driving characteristics and features.

- Read the whole manual and ensure that it is readily available. Note that deviations may occur especially if the wheelchair is specially equipped or adapted. The wheelchair can also be equipped with accessories and equipment from other suppliers.
- From a safety perspective, it is important that the maintenance instructions (see Section 8) are followed. A good rule is to keep the seat clean and periodically test the controls and brakes.
- Especially when the chair has been transported, a further check should be done to note that no cables or the like have been damaged.
- If damage is detected or any detail found to be missing, the wheelchair must be taken out of service until this is fixed.
- The wheelchair should be operated and used judiciously to avoid unnecessary risks.
- The wheelchair is not intended to be operated by children.
- Be aware that certain items of clothing are not suitable for the user to wear as they may get caught in the wheels. Be especially careful with scarves and similar items that can be tightened around the user's neck if they get caught.
- If the wheelchair is exposed to external heat sources such as sunlight, some parts may become hot. Pay attention to this so that the user is not harmed.
- Be careful with all wires so that they do not get damaged.
- The user might accidentally slide out of the wheelchair, be aware of this. See info regarding belts.

#### RISK OF TIPPING

- The risk of the wheelchair tipping backwards will increase if the seat is equipped with an increased seat tilt capacity. In these cases, the risk of tipping is always evaluated on an individual basis.
- Keep in mind that the risk of tipping also increases when bags/oxygen bottles are hung on the seat back, especially if the seat is at the maximum backward tilt.

- In addition, some users have involuntary movements or are very active, and want to grab hold of solid objects (e.g. door frames, handles). Use caution with these users and be aware when their behaviour can tip the wheelchair. Avoid parking near fixed objects.

#### RISK OF PINCHING

- Since the chair has many different configuration options, the caregiver should be aware of the user's position in the chair, to avoid the possibility that the user could become trapped. Normally the risk of pinching is small.
- Remember that the user cannot always communicate that a pinching injury is occurring.

#### MOVING IN TO AND OUT OF THE WHEELCHAIR

- Moving in to and out of the wheelchair can be done in different way depending on the user's ability to actively participate. It can be done independently, with help of one or two caregivers, or with a lift.
- The wheelchair brakes must be locked before moving in or out.
- Remove or fold in legrests fully so they do not hinder. If needed foot plates can be folded up.
- Seat tilt and back recline may need to be adjusted per the particular needs of the user.
- Caregivers need to be mindful of their ergonomic positioning when assisting.

#### LIFTING

This advice is general since there are many different lifting aids available.

- When lifting in and out of the chair, be very attentive that the user's arms and legs do not get caught. Fold in the leg rests or remove them so that they do not get in the way. Follow the lifting aid instructions carefully.
- Often training is a requirement for operating the lifting aid.

#### CE MARKED ACCESSORIES / CUSTOMIZING

- HD Rehab has a wide range of CE-marked accessories that are authorized for use with the wheelchair while maintaining the CE marking. There are also combination agreements covering accessories from other manufacturers that are approved for use on HD Balance while maintaining the CE marking. Accessories that have not been approved may not be used.
- Any change to the wheelchair or use of accessories not certified and CE-marked by HD Rehab is a special adaptation. Wheelchairs customized without HD Rehab approval do not retain HD Rehab CE marking and the warranty is void. A transfer of liability then occurs. Always consult HD Rehab if unsure about what applies. We can help with special adaptations for individual users.

#### DAILY FUNCTIONAL CHECK

To ensure that the chair works as it should, a daily function test should be performed before the user is positioned in the seat. See section **6. Daily functional checks**.

#### REPLACEMENT PARTS AND SERVICE

If the wheelchair is in need of replacement parts or service contact the reseller.

#### SAFETY NOTICES AND PRODUCT RECALLS

Information regarding any safety notices and product recalls can be found at [hdrehab.com](http://hdrehab.com).

#### WARNINGS

In addition to these general safety aspects there are warnings and notices contained in each section in the manual. They are marked with an exclamation point as follows:



- Here is the warning

### 2.3 Tests

EN and ISO wheelchair tests and crash test have been carried out for HD Balance at RISE Research Institutes of Sweden, Borås, Sweden. EN and ISO resistance to ignition tests have been carried out at SP, Borås, Sweden. More information and certificates are found at [hdrehab.com](http://hdrehab.com).

## 2.4 Identification of the wheelchair

Manufacturer, year of manufacture, serial number (SN), and article number (REF) in text and bar code formats are printed on the front cross tube of the wheel frame, see diagram 1.

## 2.5 The wheelchair parts

- |                    |                          |
|--------------------|--------------------------|
| 1 Wheel frame ●    | 9 Push bar/handles       |
| 2 Seat frame ●     | 10 Tip protection        |
| 3 Back frame ●     | 11 Leg rest              |
| 4 Back system ○    | 12 Calf support          |
| 5 Drive wheels     | 13 Footrest              |
| 6 Castors          | 14 Armrest, side support |
| 7 Caregiver brakes | 15 Tilt plate ○          |
| 8 User brake       |                          |

## 2.6 Delivery Inspection/Installation

ALWAYS DO THE FOLLOWING ON DELIVERY:

- Check that the seat does not have any visible damage.
- Any shipping damage must be reported immediately to the transport company.

Then follow the instructions in the unpacking instructions that come with the delivery. This can be supplemented with further instructions depending on the wheelchairs equipment.

## 2.7 Symbols / Markings

The following markings are on the wheelchair.



Model label. Shows that the model is HD Balance, as well as the drive wheel size and the seat width of the wheelchair.



CE marking. Shows that the wheelchair is a CE marked medical device and who the manufacturer is. SN stands for serial number and REF for reference number.

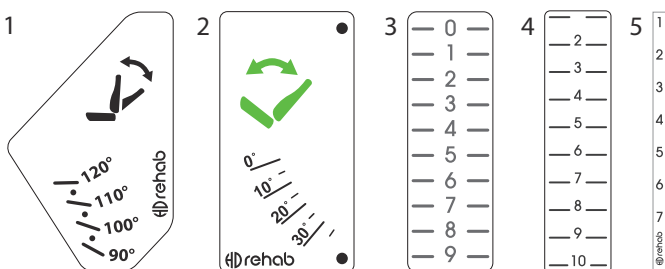

Scales. Indicates the angle of the backrest in relation to the seat (1), the seat tilt angle (2), knee joining position (3), armrest position (4), and seat depth (5). The scales are used in conjunction with the user card, where the recommended settings are recorded. See section 4.7 User Card.

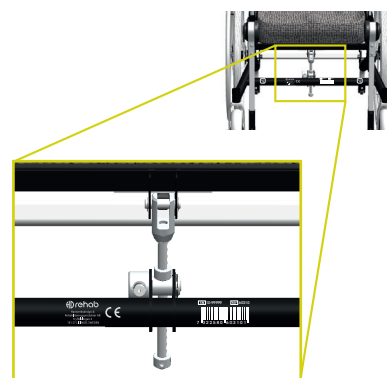

Diagram 1. Labels for wheelchair identification

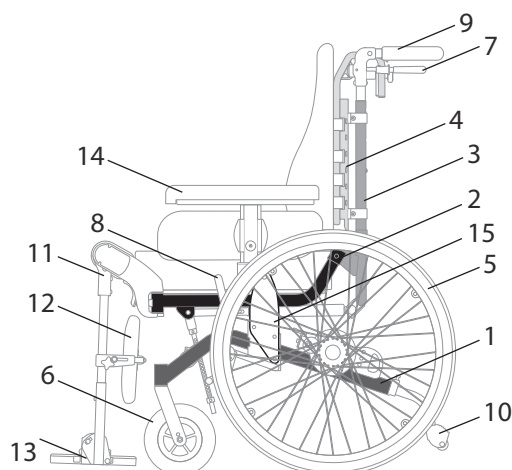

Diagram 2. The parts of the wheelchair



Parking brake. Shows how the sleeve on the brake lever is moved to activate the parking brake.



Transport bracket. Marks the attachment points for transport.



Max user weight. Shows the maximum allowable user weight for the wheelchair.



Attention required. Wheelchairs with accessories or alternate adaptations that can carry increased or different risks are marked with this symbol. Read the attached document 95706-1, Special design and accessories. Also see document 95707-1, Risk information about special configurations and accessories ([www.hdrehab.com](http://www.hdrehab.com)).

### 3. FUNCTIONS AND SETTINGS

#### 3.1 Brakes

HD Balance can be supplied with two different types of brakes; combined service and parking disc brakes (1 in Diagram 3) and user brake (2 in Diagram 3).

##### COMBINED SERVICE AND PARKING BRAKE

The brake levers are located under the push bar/push handles operated by caregivers from behind the chair. The brakes are operated by pressing the brake levers (1 in Diagram 4) against the push bar/push handles. Hold the brake levers slightly pressed to achieve a braking effect for example when moving downhill.

The parking brake is activated by pressing the brake levers up against the push bar/push handles. In this position, move the locking sleeve (a in Diagram 5) forward so that the brake lever is locked in the brake mode, see Diagram 5. NOTE: Make sure the locking sleeve is pushed forward sufficiently so that it sits securely.

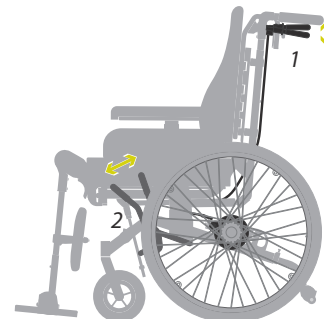

Diagram 3.

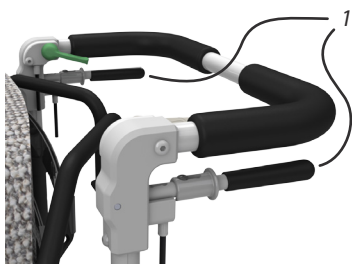

Diagram 4.

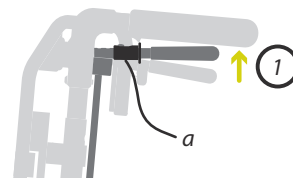
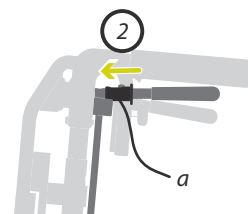

Diagram 5.



- ⚠ - Adjustment of the disc brakes should only be undertaken by a qualified technician. Information is available in "Technical information", art. no. 95720-1.

##### PARKING BRAKE / USER BRAKE

This brake works directly against the tire.

- ⚠ - If the wheelchair is equipped with pneumatic wheels, it is important that the tires are kept inflated for the wheel lock to function properly. The recommend air pressure is indicated on the tires. Normally the air pressure is 300 kPa.

To brake, move the brake levers forward from the wheels. To release the brakes, move the brake levers back towards the wheels.

Adjustment of the user brakes must be performed by qualified personnel. Instructions are in the technical manual.

- ⚠ - Parking brakes are not suitable for use when the wheelchair is on a surface that slopes more than 7°.



### 3.2 Wheels

HD Balance is equipped with either 24", 20" or 16" drive wheels depending on model and design. Drive wheel tires are solid polyurethane as standard and equipped with quick releases. The castors are 175mm as standard but can be changed to other alternatives.

Alternatively, the wheelchair can be equipped with pneumatic tires.

#### HOW TO REMOVE THE WHEELS:

- Press the lock button (1) on the top (Balance 24") alternatively the bottom (Balance 16") of the wheel bracket, see Diagram 6.
- Remove the wheel

#### HOW TO MOUNT THE WHEEL:

- Insert the wheel axle (2) in the casing (3) on the wheel bracket, see Diagram 7.
- Press the lock button (1, Diagram 6) on the top (24") and bottom (16") of the wheel attachment.
- Press the wheel so that the three pins on the hub fit into the three holes in the brake disc.
- Release the lock button and check that the wheel is secured by pulling on it.



- Make sure the lock button has slid out and that the wheel is fixed.
- Be careful not to allow the user's fingers/hands to go into the wheels.

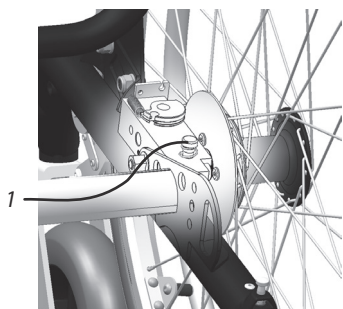

Diagram 6. The lock button for the wheel on the 24" model.

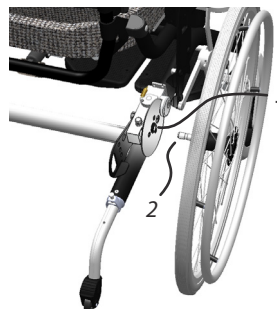

Diagram 7. Wheel axle (2) and sleeve (3).

### 3.3 Antitip device/tipping bar

Antitip devices are standard equipment on HD Balance and should always be used. The antitip devices can be set in three positions by means of a snap lock, see Diagram 8. The snap lock is unlocked by lifting the pin (1, Diagram 8). It is also possible to turn up the antitip devices temporarily to assist in passing over a curb or similar obstacle, see Diagram 9.

The antitip device can also be used as a tipping bar, i.e. provides resistance to the operator's foot when the wheelchair is tipped back on the rear wheels. The antitip devices are slightly different between the 16" and 24" models.



- Always ensure that the snap lock locks firmly into place so that the antitip device is locked.
- Make sure that correct model of antitip device is used for the wheelchair.

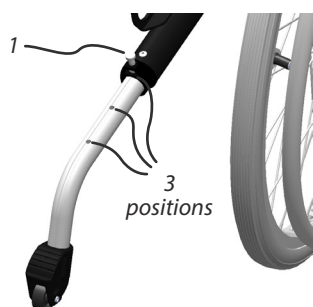

Diagram 8. The three modes of the antitip device, which are set with a snap lock.



Diagram 9. Antitip device in angled position.

### 3.4 Push bar

#### HEIGHT ADJUSTMENT OF THE PUSH BAR:

- Grip the push bar (a in diagram 10) with one hand.
- Press in one snap lock (1 in diagram 11) and pull the push bar up on the same side.
- Hold the bar up and push the second snap lock (2).
- Set the push bar to the desired position.
- Ensure that both snap locks have sprung out into the holes.
- Check brake and control cables run freely and are not subject to damage. They should run along the back tube.

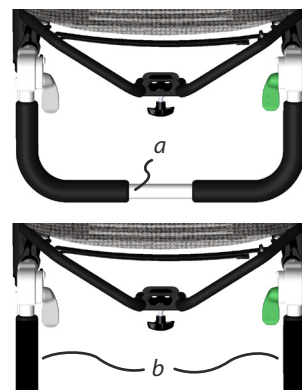

Diagram 10. Push bar and separate operating handles.

### 3.5 Separate operating handles

The wheelchair can alternatively be equipped with separate operating handles (b), Diagram 10.

#### HANDLE HEIGHT ADJUSTMENT:

- Loosen the screws, 1 & 2 in Diagram 11.
- Move the operating handles vertically to the desired position and tighten the screws.
- Make sure the screws are securely tightened.
- Check brake and control cables run freely and are not damaged. They should run along the back tube.



Diagram 11. The snap locks (push bar) alternatively the screws (separate operating handles) position.

### 3.6 Covers / Cushions

Seat and back cushions are attached to the wheelchair with Velcro and are therefore easily removable and interchangeable. Alternative cushions and upholstery come, for example, with incontinence protected upholstery.

-  - Check cushions regularly per the maintenance directions. Worn out cushions can cause pressure sores.

#### POSITIONING OF SEAT CUSHION

- Align the cushion over the seat plate and place it straight down. The cushion is slightly higher at the front and has a label at the rear. The underside is black and smooth.
- Make sure the cushion is secure.

#### REMOVING THE SEAT CUSHION:

- Take the front edge of the cushion and pull straight up.

#### POSITIONING OF BACK CUSHION:

- Attach the straps (1) in the upper part of the back cushion around the Flexi-back's tubes (2) with Velcro as shown in Diagram 12. If a hard back is used, attach the velcro to the back of this.
- Fold the cushion straight forward and press firmly against the back plate according to Diagram 13.
- Make sure the cushion is secure.

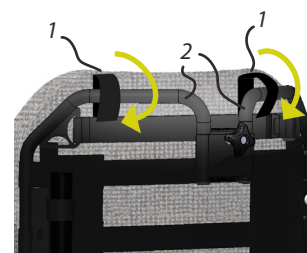

Diagram 12. Fastening straps around the Flexi-frame.

#### REMOVAL OF BACK CUSHION:

- Take hold of the lower edge of the cushion and pull up.
- Loose the straps.

#### REMOVABLE COVER

Both the seat and back cushions' covers are fitted with a zipper for easy removal and recovering. Washing instructions are on the label.



Diagram 13.

### 3.7 Seat tilt & Recline function

Diagram 16 shows the wheelchair in back reclined and seat tilted position.



- The controls should be handled with moderate force and must always be used one at a time, never at the same time.
- Never hang items on the levers.

#### SEAT TILT

The seat tilt is controlled by the green lever on the right side of the push bar (or right push handle), 1 in Diagram 14. As standard, the seat can be tilted between 0-20° in about 10 steps. Increased seat tilt is available as an alternative (longer tilt bar), providing up to 30° of tilt. Be aware that the tilt risk is slightly higher with increased tilt.

It is also possible to allow for negative tilt (forward), up to -5°.



Diagram 14. Controls for the seat tilt (1) and recline functions (2).



- The seat will not tilt forward as standard; this must be actively selected when ordering or be adjusted by competent staff later. If a forward bias is required, special attention must be paid to the user as there is a risk that the user slides off the chair. It is particularly important when users are left alone.

#### HOW TO OPERATE THE SEAT TILT:

- Grip the push bar/operating handles with both hands.
- Release the tilt lock by pressing the green lever down gently and hold it down. Pay attention when the lock is released, depending on the seat's position a different amount of force is required to resist movement.
- Set the desired angle by tilting the seat unit and then releasing the green lever.
- Make sure that the tilt lock locks properly by trying to tilt the seat without pressing the lever.

#### TILT LOCK

The seat angle adjustment mechanism and the tilt lock are fitted with an adjustable brake, see Diagram 15. Brake (1) is adjusted with a screwdriver to the desired resistance.

This adjustment should be performed by qualified personnel.

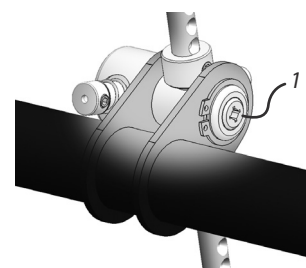

Diagram 15. The tilt lock's adjustable brake (1) that controls the inertia of the seat angle movement.

#### BACK RECLINE

The back angle is controlled by the gray lever on the left side of the push bar (or left operating handle), 2 in Diagram 14. By default the back can be angled 30° (90-120°) continuously. A gas spring provides supporting force when lifting up, but it also makes the back heavy to recline if no one is sitting in the chair.

#### HOW TO OPERATE THE RECLINE FUNCTION:

- Grip the push bar/operating handles with both hands.
- Release the lock by pressing the gray lever downwards and hold it down.
- Set the desired recline angle by pushing on the push bar and then releasing the gray lever.



- Risks exist for some accessories when changing back angle, for example pinching towards a tray table when raising the back. Similar risks also exist for belt, pommel, and hemiplegic armrest.

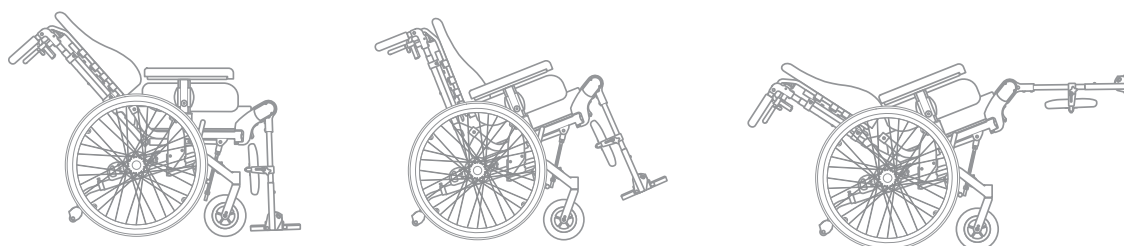

Diagram 16. Three positions. Maximum recline, maximum seat tilt, and both recline and tilt in their maximum positions.

### 3.8 Backrest Height

The height of the Flexi-back backrest can be adjusted approximately 5 cm in the tracks where it is secured to the back frame. This requires a 10mm key, diagram 17, which is located under the front seat's cross tube.

As an alternative for tall users there is an extended Flexi-back that is 10cm higher than standard.

#### HEIGHT ADJUSTMENT OF THE BACKREST:

- Loosen the four nuts, 1 in Diagram 18, a few turns.
- Push the Flexi-back up or down to the desired height.
- Tighten the nuts securely.
- Make sure the brake cables are not damaged during adjustment.

If the backrest needs to be even higher, the four clamps the Flexi-back is attached to are moved upward along the back frame tubes. This makes the backrest position a further 30mm higher. Steps:

- Loosen the four back clamps by loosening the screws, 2 in Diagram 19, a few turns.
- Push the back clamps carefully along the back frame tube to the desired position. Some risk of damage to the paint finish exists. *Note that the top position for the push bar becomes unusable because the snap hole is covered.*

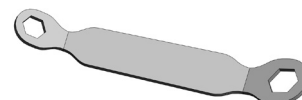

Diagram 17. The tool, which is located underneath the seat's cross tube.

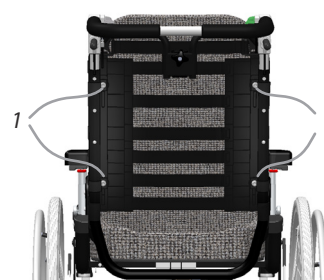

Diagram 18. The nuts for the Flexi-back height adjustment.

### 3.9 Setting the Flexi-Back

Guide for setting the Flexi-back:

1. *Before the user sits in the wheelchair;*
  - a. Release the velcro straps of the Flexi-back.
  - b. Pull the back cushion off the velcro straps, leaving it attached to the top of the Flexi-back. Fold the back cushion lengthwise. Hold it folded and push it back against the straps. Release.
  - c. Make sure the back cushion is properly positioned in the chair. See instructions under Covers / Cushions.
  - d. Loosen the nuts for height adjustment of the Flexi-back.
2. *Positioning of the user;*
  - a. When lifting the user, tilt the wheelchair's seat unit backwards. In many cases it is also helpful to recline the backrest slightly.
  - b. Position the user well into the wheelchair, between the side tubes of the Flexi-back. This is required to form the Flexi-back to the user's back.
3. *With the user sitting in the wheelchair;*
  - a. Set the Flexi-back at the desired height.
  - b. Adjust the velcro straps to suit the user's back.
  - c. Tighten the nuts for the Flexi-back height adjustment.

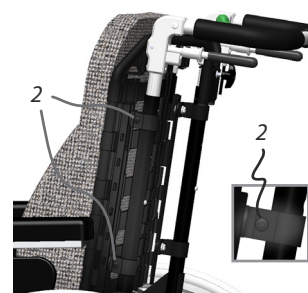

Diagram 19. The screws for adjusting the height of the back clamps.

### 3.10 Adjustable seat/seat depth

Seat depth is controlled by a lever (1) under the seat's left side, see Diagrams 20 & 21, and can be set to seven different positions.

#### DEPTH SETTING:

- Move the lever (1) outward and hold it out.
- Slide the seat plate to the desired position.
- Release the lever and slide the seat plate slightly so that the lever snaps in to a locked position.
- Check that the seat plate is securely locked.

The seat plate can be pulled out, for maintenance reasons by pulling the locking catch (2 in Diagram 21) down at the same time as the lever (1) is moved outwards. This is only done in for the purpose of maintenance.



- Make sure that the seat plate locks in position when it is put back.

### 3.11 Armrests

#### STANDARD ARMRESTS

Armrests are located in separate brackets on both sides of the seat, see Diagram 22, and can be adjusted vertically and horizontally. They consist of the following components:

- 1 Armrest pad (1 in Diagram 23)
- 2 Side support (2)
- 3 Locking button (3)
- 4 Locking lever (4)

#### HEIGHT ADJUSTMENT:

- Push button (3, Diagram 23) and hold it down.
- Set the desired height. The tube is marked with 1 cm intervals.
- Release and push/pull the arm pad until the lock snaps in place.

Maximum setting range is 9 cm.

#### DEPTH SETTING:

The arm pad can be adjusted to six depth settings as standard. If the chair has a special configuration such as a wider Flexi-back, the furthest back positions cannot be used.

- Press the locking lever, (4) in Diagram 23, and set the desired position.
- Release the locking lever.
- Make sure the plate is locked in position by pulling a bit on it.



Diagram 20. The lever (1) for seat depth adjustment is located under the left side of the seat.

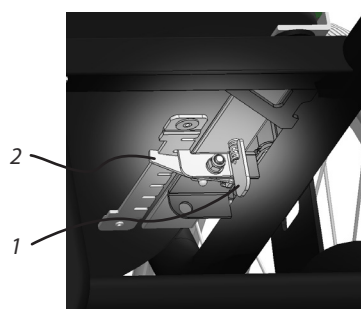

Diagram 21. The locking clasp (2) and the lever for seat depth adjustment (1) as seen from below.



Diagram 22. The armrests are inserted into the brackets on each side of the seat frame.

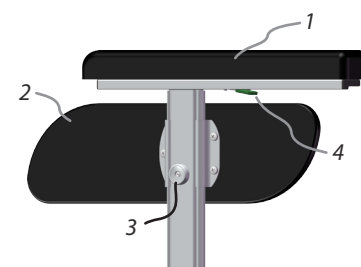

Diagram 23. Armrest parts.

## 3.12 Leg rest

### ANGLE ADJUSTABLE LEG RESTS

Angle adjustable leg rests are standard on HD Balance. They can be angled between 90° (straight down) and 180° (straight out) with 10° steps (10 positions).

Components see Diagram 24:

- 1 Locking lever for removal of leg rests
- 2 Angle control, release button
- 3 Leg rest tube
- 4 Cap, outside
- 5 Padding, inside
- 6 Knee joint
- 7 Turnable link
- 8 Snap lock, footrest

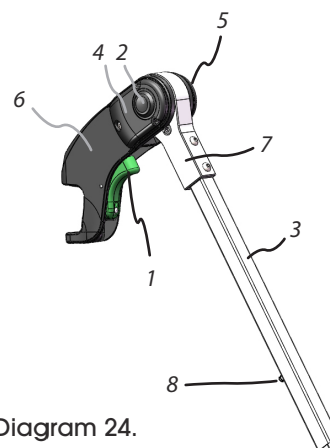

Diagram 24.

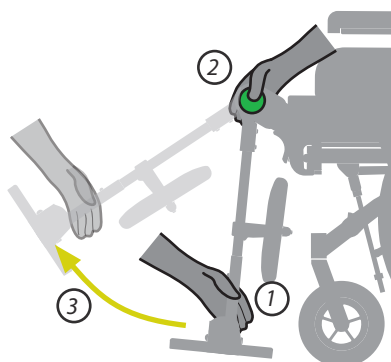

Diagram 25. Angling of legrest.

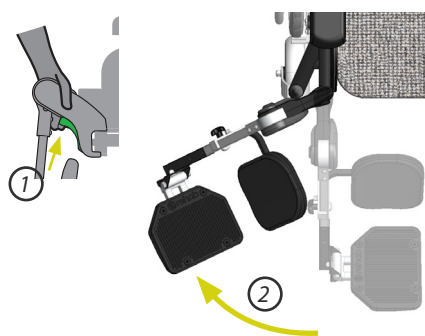

Diagram 26. Turning out legrest.

### ANGLING OF LEG RESTS

- Grip the leg rest tube as far down as possible (1 in Diagram 25). Lift slightly to ease the load on the locking mechanism.
- Push button on the outside of the knee joint (2 in Diagram 25) and move the leg rest to the desired position (3 in Diagram 25).
- Release the button and move the leg rest in either direction so that leg angle mechanism snaps into the locked position.

### TURNING OUT LEG RESTS

The leg rests can be angled out by about 90 degrees for better access in and out of the chair. In order to angle them out, grip the knee joint from above and push in the locking lever (1 in Diagram 26), then turn the leg rest (2 in Diagram 26).

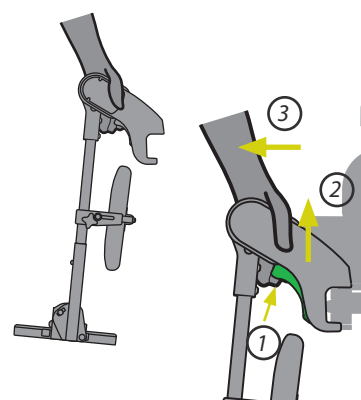

Diagram 27. Removal of legrest.

### REMOVAL OF LEG RESTS

- Grip the knee joint from above and press in the locking lever (1 in diagram 27).
- Lift straight up until the leg rest is loose (2 in diagram 27).
- The leg rest can then be lifted out without the user's legs needing to be stretched (3 in diagram 27).

Alternatively, the leg rest can first be turned out and then lifted off.

### MOUNTING LEGRESTS

- Grip around the knee joint press in the locking lever (1 in diagram 28).
- Move the knee joint just above the bracket on the wheelchair.
- Align the hole with the peg on the seat frame and slide it down (2 in diagram 28).
- Turn the knee joint so that it points straight ahead and ensure that the locking pin clicks in.

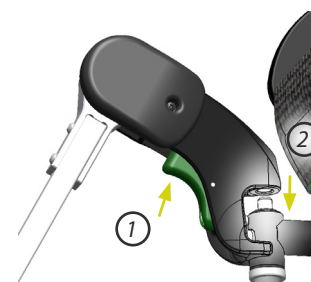

Diagram 28. Mounting legrest.

## FIXED-ANGLE LEG RESTS

Alternatively, the wheelchair can be equipped with fixed-angle leg rests. These are available with different angles.

### MOUNTING FIXED-ANGLE LEG RESTS

- Align the hole in the knee joint over the peg and let the knee joint slide down, see Diagram 29. It may be easier if the lever (1) is moved forward.
- Release the lever (1) and rotate the leg rest to point straight ahead, make sure that the locking pin clicks in and locks the knee joint (Diagram 30).

### REMOVAL/ANGLING OF FIXED-ANGLE LEG RESTS

- Grip the leg rest and move the lever (1) forwards.
- Turn out/lift off the leg rest.

### AMPUTEE LEG REST

For information about use and mounting of the amputee leg rest, see separate User manual/Assembly instructions.

## 3.13 Footrest

### FOLD-UP FOOTPLATE

Footplates can be folded up to facilitate entry and exit, see Diagram 31a.

### HEIGHT SETTING FOOT REST

Press the snap lock, (2) in Diagram 32, and move the footrest tube to the desired position.

### DEPTH SETTING OF FOOT PLATE

The foot plate depth can be adjusted in 3 mounting positions.

- Remove the two screws and washers (1), see diagram 31b.
- Remove the footplate and place it back in the desired position.
- Screw the footplate in place with the screws and washers.

Note that the footplate is available in two sizes, one size for seat widths 38 and 42, one size for seat widths 46 and 50. The foot plate is adjusted in depth to suit the seat width (diagram 31b).

### ANGLE SETTING OF FOOTRESTS

- Loosen the lock nut (3), see Diagram 32.
- Tilt the foot plate to the desired position.
- Tighten the lock nut securely

## 3.14 Calf support

### DEPTH SETTING OF CALF SUPPORT

- Loosen the lock nut a few turns (4 in Diagram 32).
- Slide the calf plate to the desired position.
- Tighten the nut securely.

### HEIGHT ADJUSTMENT CALF SUPPORT

The height of the calf support is adjustable along the leg rest tube. Loosen the knob (5 in Diagram 32), then pull the calf support to the desired position and tighten the knob.

### LATERAL ADJUSTMENT CALF SUPPORT

As of spring 2015 the calf support can also be adjusted laterally.

- Loosen the screw a few turns (6 in Diagram 32).
- Slide the calf support pad to the desired position.
- Tighten the screw.

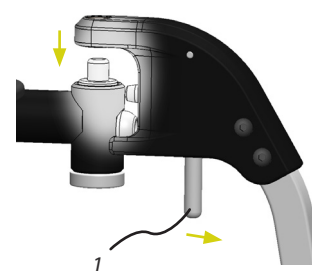

Diagram 29. Mounting of the fixed-angle legrests.

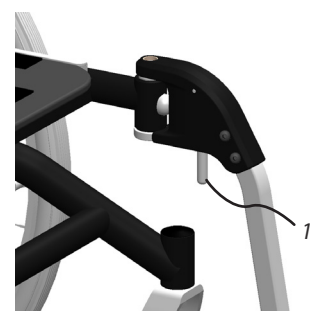

Diagram 30. Fixed-angle legrests in place.

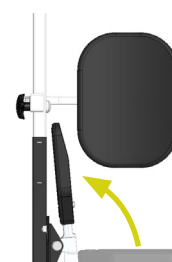

Diagram 31a. Folding up the footrest.

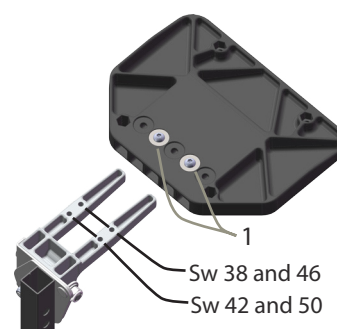

Diagram 31b. Footplate adjustment.

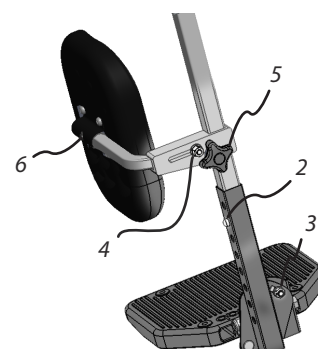

Diagram 32. Footrest and calf support.

## 4. ACCESSORIES

This section briefly describes some of the accessories that are available for HD Balance. They are all CE labelled and approved for use with the wheelchair. More information about the respective accessories is available as information sheets. Instructions on how accessories are installed can be found in the respective accessory installation instructions. For more information please visit [www.hdrehab.com](http://www.hdrehab.com).



- Never use accessories that are not approved for HD Balance. The wheelchair is then considered a custom product, read more in **2.2. General Safety Aspects.**

### 4.1 Headrest / Neck rest

The headrest (Diagram 33) and neck rest (Diagram 34) each consist of two parts: an extension tube (1, Diagrams 33 & 34) and a cushion with a headrest tube (2). The cushion is slightly smaller on the neck rest than on the headrest.

Set the tube in the bracket (3 in Diagrams 33 & 35) on the rear of the back by sliding it down through the sleeve to the desired position and tighten the knob (7, Diagram 35).

Note: Do not tighten too hard as the knob and bracket can be damaged.

#### LATERAL ADJUSTMENT:

If necessary, some models of headrests and neck rests can be adjusted laterally to suit the user's head position.

- Loosen the screws (6 in Diagrams 33 & 34).
- Move the headrest to the desired position and tighten the screws.

The cushion is shaped to provide support at the base of the skull so that the head can be positioned in a balanced comfortable position.

#### LATERAL SUPPORT FOR THE HEADREST & NECKREST

Some models of headrests/neck rests can be equipped with one or two removable lateral supports (4, Diagram 33) to increase lateral stability. In this case the back of the main headrest is fitted with 2 stand sleeves (5) to adjust the positions of the lateral supports.



- Do not hang things on the headrest/neck rest.
- Some users with particular/involuntary movements might risk to get caught between the rest and the wheelchair. Individual assessments must be done to determine what type of support is suitable.

### 4.2 Bag hook

The bag hook (1, Diagram 36) is mounted on the operating handle tube (2) under the operating handle joint (3). The hook is clamped to the pipe by tightening the screw (4).

On installation and use of the bag hook, ensure that the brake cables (5) are not damaged.



- A maximum of 5kg total may be hung on the bag hook.
- When bags etc. are hung on the bag hook the risk increases of tipping backwards. How much depends on the weight and the back-and seat angle settings.
- It is the responsibility of the caregiver/user to check the risk of tipping and to make sure the antitip devices are used.

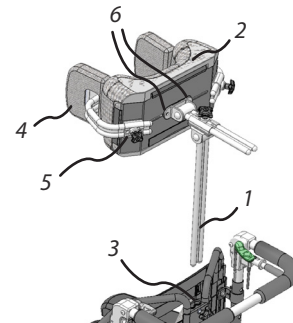

Diagram 33. Headrest with lateral supports.



Diagram 34. Neckrest.

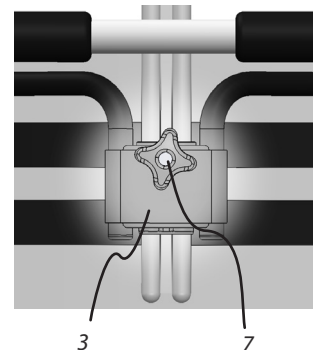

Diagram 35. Headrest mount.

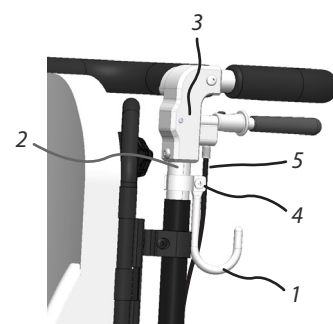

Diagram 36. Bag hook mounted.



### 4.3 Thoracic support

The thoracic support, which is available in various models, is mounted by inserting the hook (1 in Diagram 37 & 38) in the thoracic support fastening (2) on the rear of the back and tightening with the knob (3) in the desired position.

Note: Do not tighten too hard as the knob/bracket can be damaged.

The cover is removable and mounted with velcro. Washing instructions are on the labels.

#### HEIGHT ADJUSTMENT

See separate installation instructions.



- Note that the use of the thoracic support requires thorough testing to ensure the user receives good support and that the thoracic support does not cause pressure that can lead to injury.
- Avoid placing the thoracic support near the user's armpit since the area is generally considered to be intimate and pressure sensitive.

### 4.4 Tray Table

The tray table, which is available in various models, is intended to be used to put smaller things on and in some cases to position the user by working as a support for the lower arms.

Installation is done by inserting the two pins (1, Diagram 39) on the table top into the table bracket (2) on the outside of the armrests.

The table brackets can be easily adjusted for depth by sliding them along the rail under the arm pad. Loosen the screws underneath, slide the bracket along the track and tighten the screws in the desired position.

Keep in mind that armrests should be placed at the same height and depth so that the tray table sits evenly.

A version with lock is available. Push the button and hold to lock and unlock the mechanism, see Diagram 40.



- When using a tray table there is a risk of pinching when the back is lifted up from a reclined position.
- The tray table is not intended for heavy loads. Maximum load is 7kg.
- Restrictions may exist regarding the use of a tray table if it restrains the user from getting out of the wheelchair, especially when using the version with lock. Be aware of local regulations.
- Do not sit on the tray table.

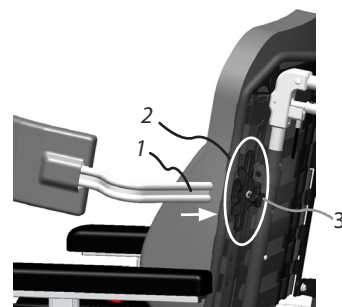

Diagram 37. Thoracic support and fastening (circled).

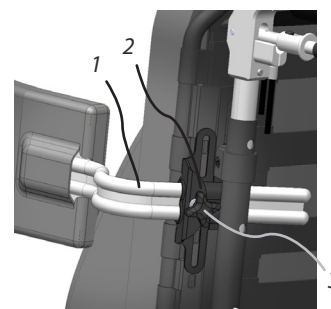

Diagram 38. Thoracic support mounted in the fastening.

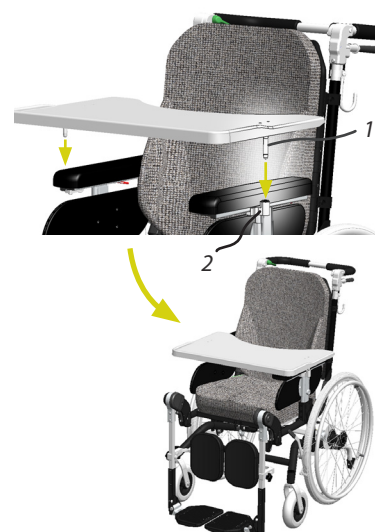

Diagram 39. Table mounting.

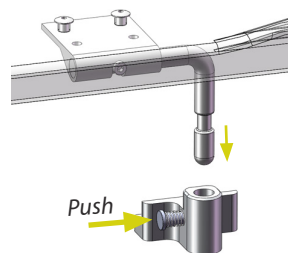

Diagram 40. Table lock mechanism.

## 4.5 Pommel

The pommel consists of (see Diagram 41):

1. Pommel cushion
2. Mounting profile
3. Mount with knob

The same mount is used for all pommel versions.

The pommel is attached by inserting the mounting profile into the mount and securing with the knob. See Diagram 42.

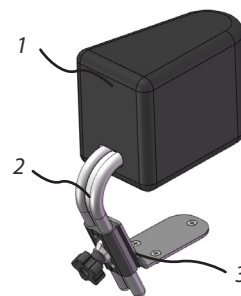

Diagram 41. Pommel with mount.

### SETTING DEPTH (NOT AVAILABLE FOR SOME MODELS)

- Open the cover on the underside of the pommel cushion
- Loosen the screw
- Move the pommel on the mounting profile to the desired position and tighten the screw.

## 4.6 Positioning Belt / Harness

If there is a risk that the user can slide out of the chair a positioning belt can be used.

The belt is available in two versions, a 2-point belt and a 4-point harness. These are used with belt fasteners, Diagrams 45 & 46

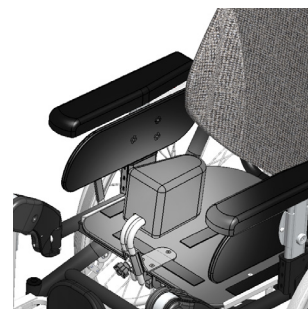

Diagram 42. Pommel mounted on wheelchair.

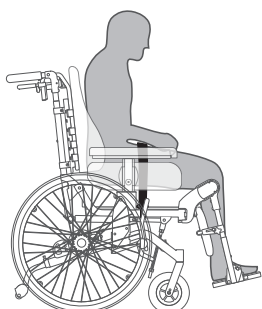

Diagram 43. 2-point belt.

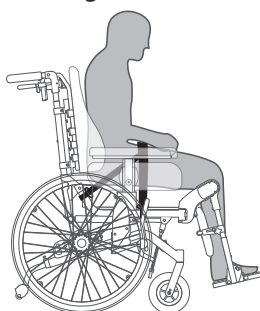

Diagram 44. 4-point harness.



Diagram 45. Belt fastener.

### 2-POINT BELT, DIAGRAM 43

The 2-point belt is attached to the two belt mounts, one on each side. It is important that the brackets are placed correctly so that the user's position is good. Always have qualified personnel install them.

### 4-POINT HARNESS, DIAGRAM 44

The 4-point harness is attached to the four belt mounts, two on each side. It is important that the brackets are placed correctly so that the user's position is good. Always have qualified personnel install them.

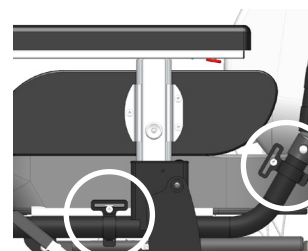

Diagram 46. Belt fastener attached (circled).



- There may be special restrictions on use of the belt.
- Individually adapted information about the use of belt must be received from the prescriber for each user.
- Pay attention to the use of positioning belt. There is a risk that the user slides down in the chair and gets stuck in the belt if it is incorrectly installed or poorly fastened. This can lead to impaired blood/oxygen supply and risk of the user choking.
- Always make sure that the belt is securely fastened when used.
- If possible, tighten the belt when in an upright position. If the belt is tightened when the back is in a reclined position it may cause pinching when the back is later raised.
- Be aware of loose belts, they can get caught in the wheels and cause a sudden stop or pinching.

## 4.7 User Card

A User Card is attached to the back of the wheelchair and is used to ensure the user's seated position is according to the recommendations of the prescriber. The prescriber (or other authorized person) can communicate the recommended settings for each individual patient. Diagram 47 explains how the card should be interpreted. The different settings are read from the wheelchair from the markings described in section 2.7 *Symbols / Markings*.

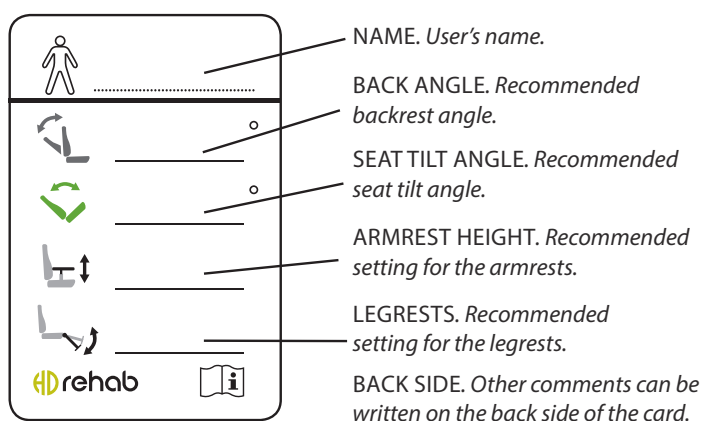

Diagram 47. User Card

## 5. TRANSPORT

### 5.1 Transport of wheelchair with patient in vehicles

HD Balance must be held in place in the vehicle with a 4-point belt system, see Diagram 48, and the user must use a 3-point safety belt. Both must be approved according to ISO 10542-2. All transportation must be done with the wheelchair facing forwards. See Diagram 49.



Diagram 48. Wheelchair with straps mounted.

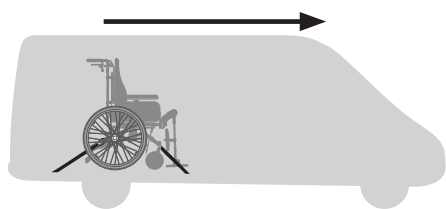

Diagram 49. All transport must be forward facing.

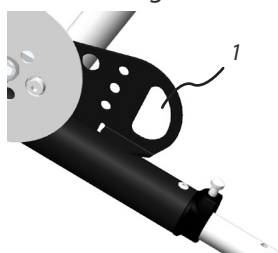

Diagram 50. Rear transport mount.



Diagram 51. Front tensioning during transport.

When strapping down the wheelchair the rear tension device is attached to the intended mounts on the wheel frame, see 1 in Diagrams 48 & 50. The front tension device is attached around the cross tube of the wheel frame; see 2 in Diagrams 48 & 51. These attachment points are marked with the symbol described in section 2.7 *Symbols / Markings*.



- No other attachment points than those specified may be used.

#### THE FOLLOWING MUST BE CONSIDERED BEFORE TRANSPORT:

- Tray table, thoracic support, and other accessories must be removed.
- The headrest/neck rest must be used.
- Seat tilt and back recline must be positioned as upright as possible.
- The leg rests must be angled down as much as possible.
- Do not use too much tension. Tensioners should only be tightened so that the wheelchair is stable. Any rocking may not be offset by tightening the straps tighter. Tensioning devices can create excessive loads on the wheels and frame components and thereby damage the wheelchair.
- The user must always use the vehicles fixed system of three-point safety belts. Any positioning/safety belts that are mounted on the wheelchair and are usually used by the patient may not be used as substitutes for seat belts when travelling in vehicles.

HD Balance is crash tested according to ISO 7176-19:2008 (see Section 9.1 there), which means that it has been tested and passed the requirements of a standard test. The test simulates a frontal collision at 48 km/h with a test dummy weighing 79,2 kg. The standard specifies a minimum requirement for what the wheelchair must withstand regarding transport in a vehicle.

Since an actual incident is likely to be different than the conditions at the time of testing, HD Rehab does not accept any responsibility for the outcome of an accident in which HD Balance is involved.

## 5.2 Weight of removable components

Wheel 24"	2,0 kg	Leg rest	2,4 kg	Seat cushion	ca 1,1 kg
Wheel 16"	1,9 kg	Armrest	1,1 kg	Back cushion	ca 0,8 kg

## 5.3 Folding the wheelchair for transportation

### FOLDING OF WHEELCHAIR

- Tilt the seat unit to its most forward position.
- Remove the armrests and any accessories such as thoracic support andommel, as well as cushions.
- Remove the leg rests if it is advantageous.
- Grasp the push bar with one hand and pull the locking pin, (1) in Diagram 52. The gas spring (2) then drops down from the mount (3) and the backrest can be folded forward against the seat, see Diagram 53.
- The drive wheels may be removed to make the wheelchair even smaller.

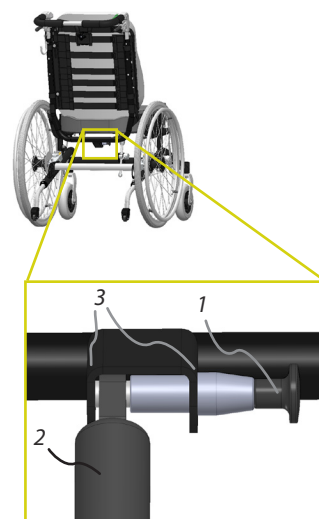

Diagram 52. Locking pin for folding.

### RE-ASSEMBLY AFTER FOLDING

- Raise the backrest.
- Pull the pin (1), and fit the gas spring in the mount.
- Slip the pin through the gas spring's mounting hole (4, Diagram 54) and completely through both plates of the bracket (3, Diagram 52).

### CHECKLIST AFTER TRANSPORTATION

- Make sure the pin (1) goes fully through the bracket (3), Diagram 52.
- Check that the wheels are securely fastened.
- Make sure the antitip devices are positioned correctly.
- Check the most important functions; brakes, seat tilt, back recline.



- If the pin is not properly mounted, the bracket can break and the patient will be suddenly tipped backwards.

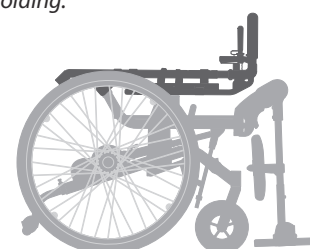

Diagram 53. Folded.



Diagram 54. The gas spring's mounting hole.

## 5.4 Transferring in and out of the wheelchair

Transferring in and out of the wheelchair can be done in different ways depending on the user's ability to actively participate. It can be done with a lift, with help of one or two caregivers, or independently.

- The brakes must be locked before transferring in or out.
- Remove or fold in leg rests fully so they do not hinder. If needed foot plates can be folded up.
- Seat tilt and back recline may need to be adjusted per the particular needs of the user.
- Caregivers need to be mindful of their ergonomic positioning when assisting.

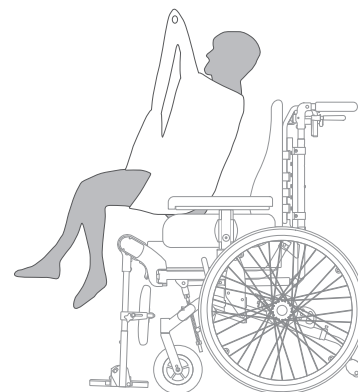

Diagram 55. Transfer with lift

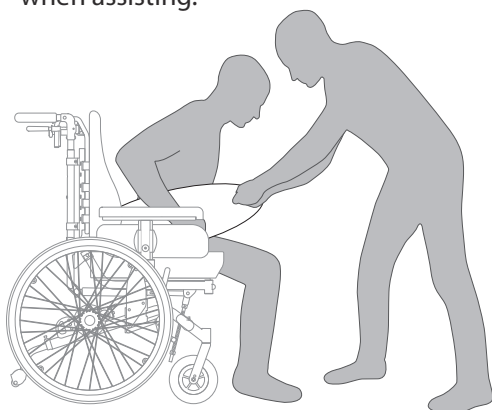

Diagram 56. Transfer with assistance

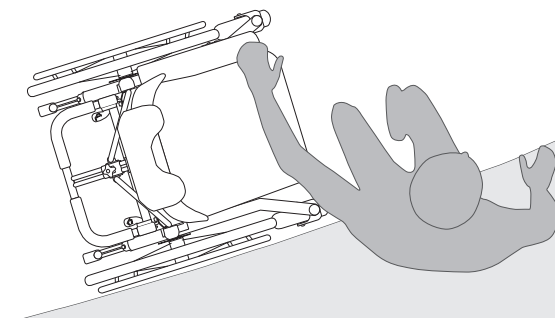

Diagram 57. Independent transfer

## 5.5 Driving Technique

### SLOPED SURFACES

When a user drives the wheelchair independently up a slope the wheelchair is balanced by the user leaning forward. When driving down a slope the user leans backward to balance the weight. Speed is controlled by using the drive rings.

On steeper slopes the wheelchair should be driven by a caregiver. Antitip devices must always be turned to the active position.

- Steep surfaces should be avoided due to the increased tipping risk.
- Surfaces that are wet, slipper, or uneven increase the risk of the wheelchair slipping or tipping.
- The wheelchair should not be turned on a sloped surface due to the increased tipping risk.
- When driving down a slope ensure that the user cannot slide out of the wheelchair (Diagram 58).

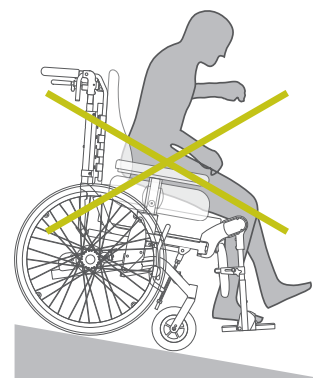

Diagram 58. Sloped surface.

### CURBS / OBSTACLES - UPWARD WITH CAREGIVER

Tip the wheelchair up on the rear wheels by pushing down on the push bar and holding with a foot on the tipping bar. Place the castors on the higher surface, lift on the push bar and roll the wheelchair up. See Diagram 59.

- As caregiver remember to use a good ergonomic position.
- In some cases it may be necessary to turn up the antitip devices, remember to turn them down again after moving.
- With a heavy user, tilt the seat back before tipping the wheelchair up. This reduces the amount of force required of the caregiver.

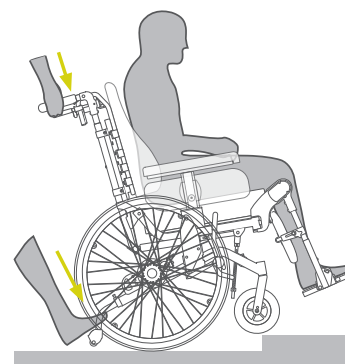

Diagram 59. Curb.

### CURBS / OBSTACLES - DOWNWARD WITH CAREGIVER

Back the wheelchair carefully down the edge. Balance with the push bar until the castors have reached the lower surface.

- As caregiver remember to use a good ergonomic position.
- In some cases it may be necessary to turn up the antitip devices, remember to turn them down again after moving.

### STAIRS

Moving from one floor to another always comes with risk of injury for the user and the caregivers. The preferred choice is therefore to use an elevator. When there is no elevator, a ramp should be used. If there is no ramp and stairs must be used, two caregivers should move the wheelchair and user.

#### UP STAIRS WITH CAREGIVERS - BACKWARDS

Before the wheelchair is moved up stairs the antitip devices must be turned up or removed. The wheelchair is balanced up on the back wheels. The caregiver behind the wheelchair lifts and pulls on the push bar. The caregiver in front of the wheelchair supports and lifts on the seat frame such that the wheelchair carefully glides over each step. The caregivers must be careful with their positioning to avoid injury. Return antitip devices to the active position after moving. See Diagram 60.

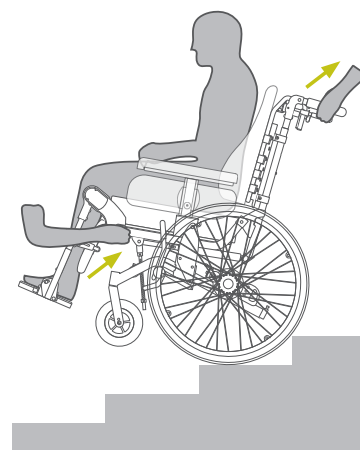

Diagram 60. Stairs.

#### DOWN STAIRS WITH CAREGIVERS - FORWARD

Turn up the antitip devices. The wheelchair is balanced up on the back wheels. The caregiver behind the wheelchair rolls the wheels down each step and holds back on the push bar. The caregiver in front supports with hands on the frame such that the wheelchair carefully glides down each step. Return antitip devices to the active position after moving.

- The wheelchair is not to be moved on an escalator.
- Never lift on the armrests or other unsecured parts.

## 6. MAINTENANCE AND CARE

For safety and long life the wheelchair should be kept clean and tidy. Any faults and failures must be addressed immediately. Estimated lifetime is 10 years under normal use with the same patient during the entire lifetime, assuming maintenance is carried out according to the instructions. How the chair is used affects the need for maintenance; hard wear, patients with particular movements, and much outdoor use require more maintenance and shorten the lifetime. Table 2 details the maintenance to be carried out.

<b>Table 2.</b> <b>Activity</b>	Ongoing as necessary	1-2 times per year	At least every 3rd year
Cleaning of painted and coated surfaces and plastic parts	x		
Cleaning of upholstery, see label on the upholstery	x		
Checking all screws, bolts, and nuts		x	
Control of castor wheels		x	
Control of antitip devices		x	
Control of the chassis		x	
Checking the brakes		x	
Control of seat tilt and back recline functions		x	
Control of the locking pin (back folding)		x	
Control of the cushions		x	
Control of tilt lock		x	
Control and maintenance of accessories (Functionality, lockings, markings)		x	
Total reconditioning, see separate instructions, article number 95725-1 *			x

\* To be carried out by a specialist

### EXPLANATIONS FOR TABLE 2

#### COATED AND SURFACE TREATED SURFACES AND PLASTIC PARTS:

- Wash/wipe with regular all-purpose detergent or disinfecting agents. No caustic agents.

#### SCREWS, BOLTS, NUTS:

- Check all screws, bolts, and nuts; tighten any that are loose.

#### CASTOR WHEELS:

- Check that the castors spin freely and do not have any visible damage. Remove any debris.

#### ANTITIP DEVICES:

- Check that the antitip devices have no visible damage and are operating normally.

#### CHASSIS:

- Inspect the chassis for cracks, warping and other defects. Notify authorized personnel if damaged.

#### BRAKES:

- Check that the brakes work firmly (both operator and user brakes).  
- Contact a qualified technician if adjustment or lubrication is necessary.

#### SEAT TILT AND BACK RECLINE FUNCTIONS:

- Check that the controls are easy to use and that the levers do not have any damage.

#### LOCKING PIN (BACK FOLDING):

- Check that the locking pin is intact and sits properly. Check that the knob is tightly screwed on.

#### CUSHIONS & BELTS:

- Cushions wear out and become compressed, check to see if any need replacing.  
- Check that the belt attachments, velcro, and locking mechanisms work properly.

#### ARMRESTS, SIDE SUPPORTS, CALF SUPPORTS:

- Wipe with damp cloth or with disinfectant.

#### TILT LOCK:

- Remove any dirt in the holes along the rod and the spring pin where the wire is attached.  
- Check that the stop rings on the tilt bar are securely fastened.  
- If the tilt bar or wire sleeve is stiff, they can be lubricated. More info regarding lubrication type is available in "Technical info", 95720-1.  
- If it functions poorly in any other way, immediately contact authorized personnel.

TELESCOPING ALUMINUM PROFILES can be lubricated with petroleum jelly or food grade grease.

THE LATEST VERSION of the maintenance instructions (article number 95730-1) is always available at our website, [www.hdrehab.se](http://www.hdrehab.se).

## 6.1 Daily functional checks

To ensure the user's safety a daily functional check of the most vital parts should be carried out as described below.

- Test the brakes (both service brakes and user brakes).
- Check that seat tilt and back recline are functioning.
- Check that the wheels and cushions are correctly positioned, and are whole and clean.
- Check that the antitip devices are in the appropriate position.
- If the seat is equipped with a user card, make sure that the chair settings are consistent with its recommendations.

## 6.2 Long term storage

The wheelchair should be cleaned before storing long-term. Store in a dry, frost-free environment between 0 and 30°C. Cushions should be wrapped. When returning the wheelchair to service read through the user manual and check that all functions are working properly.

## 6.3 Recycling and disposal

HD Balance can for the most part be recycled. Instructions for disassembly and recycling are available in Disposal Instructions HD Balance, article number 95735-1.

## 7. TECHNICAL DATA - MEASURES

Table 1 - General measures, HD Balance Measures in [mm] unless otherwise stated	Seat width 38		Seat width 42		Seat width 46		Seat width 50	
	16"	24"	16"	24"	16"	24"	16"	24"
Maximum user weight [kg]	135		135		135		135	
Seat width	380		420		460		500	
Seat depth standard frame, with cushion	430-520		430-520		430-520		430-520	
Seat depth standard frame, without cushion	380-470		380-470		380-470		380-470	
Seat depth extended frame, with cushion	480-570		480-570		480-570		480-570	
Seat depth extended frame, without cushion	430-520		430-520		430-520		430-520	
Distance back - knee joint, standard frame	560		560		560		560	
Distance back - knee joint, extended frame	610		610		610		610	
Seat height without cushion	450		450		450		450	
Seat height with original cushion, back edge	510		510		510		510	
Seat height with original cushion, front edge	540		540		540		540	
Seat height without cushion, increased height	500		500		500		500	
Seat height without cushion, reduced height	420		420		420		420	
Seat height without cushion, 20" / 5" wheels	n/a	410	n/a	410	n/a	410	n/a	410
Back height standard, seat plate - top of back frame	550-600		550-600		550-600		550-600	
Back height extended, seat plate - top of back frame	650-700		650-700		650-700		650-700	
Back width	380		420		460		500	
Armrest height standard, from seat plate	255-345		255-345		255-345		255-345	
Armrest height low, from seat plate	195-255		195-255		195-255		195-255	
Armrest depth, from back frame reference point	340-430		340-430		340-430		340-430	
Armrest length	370		370		370		370	
Armrest width	70		70		70		70	
Leg rest angle[°]	90-180		90-180		90-180		90-180	
Footrest height, seat plate - foot plate	230-430		230-430		230-430		230-430	
Footrest angle, seat plate - foot plate [°]	90-110		90-110		90-110		90-110	
Footrest depth	210		210		210		210	
Footrest back edge - knee joint (centre)	70-110		70-110		70-110		70-110	
Calf support height	210		210		210		210	
Calf support depth, to centre of knee joint	60-90		60-90		60-90		60-90	
Push bar height, standard (3 positions)	1050-1200		1050-1200		1050-1200		1050-1200	
Total width *See also Tables 2, 3, 4	620	630	660	670	700	710	740	750
Total length, with leg rests	980		980		980		980	
Total length, without leg rests	760		760		760		760	
Total height, back in 90° position	1050		1050		1050		1050	
Total height, no cushions, back frame folded down	750		750		750		750	
Total weight [kg] including original cushions	29,8	29,9	30,1	30,2	30,4	30,5	30,7	30,8
Turning space	1340		1340		1340		1340	
Seat tilt angle [°] (-5° possible)	0 - 20		0 - 20		0 - 20		0 - 20	
Seat tilt angle, extended range [°] (-5° possible)	0 - 30		0 - 30		0 - 30		0 - 30	
Back angle [°]	90-120		90-120		90-120		90-120	
<b>Transport measures</b> (folded; without drive wheels, antitip devices, leg rests, armrest, seat and back cushions)								
Width	630		670		710		750	
Length	750		750		750		750	
Height	720		720		720		720	
Weight [kg]	16,5		16,7		16,9		17,1	



<b>Table 2 - Total width HD Balance 24</b>	<b>Balance 38</b>	<b>Balance 42</b>	<b>Balance 46</b>	<b>Balance 50</b>
Measures in [mm]				
Standard 24" wheel (6 screws per hand rim)	630	670	710	750
Older 24" wheel (4 screws per hand rim)	635	675	715	755
24" with hand rims moved in and shorter castor axle pins	615	655	695	735
24" with hand rims moved out (6 screw hand rims)	640	680	720	760

<b>Table 2 - Total width HD Balance 16</b>	<b>Balance 38</b>	<b>Balance 42</b>	<b>Balance 46</b>	<b>Balance 50</b>
Measures in [mm]				
Standard 16"	620	660	700	740
Shorter castor axle pins	615	655	695	735

<b>Table 4 - Effect on total width of different configurations and accessories</b>	
Option	Notes
Wide armrests	No change in total width.
Standard armrests with coaming	No change in total width.
Wide armrests with coaming	Total width unchanged in standard configuration. Total width is affected if used in combination with moving in hand rims / shorter castor axle pins.
Hemiplegia armrest	Total width can be affected depending on settings.
Shoulder support	No change in total width in normal use. Total width is affected if used together with a wider back system.
Table tray	No change in total width. Applies to all table tray options.
Trunk support	No change in total width. Total width is affected if used together with a wider back system.
Hand rims	No change in total width. Applies to all hand rim options.
IV pole	Total width can be affected depending on position of IV pole hooks.
Increased back width	No change in total width. Applies to both +4 cm and +8 cm.



 balance 24



 balance 16

 **rehab**



HD Rehab AB  
Tryffelsslingan 4  
181 57 Lidingö  
SWEDEN

08 - 767 04 80

[info@hdrehab.se](mailto:info@hdrehab.se)

[www.hdrehab.com](http://www.hdrehab.com)

Doc. nr. 95701-1  
User Manual  
HD Balance  
Rev G 2023-01-19

